

centormail Print Head Replacement Instructions

The centormail will remind you when you need to replace the print heads. This will be after three bulk ink tanks have been finished using the one set of print heads.

If you wish to replace the Print heads before prompted to do so by centormail, you can start the procedure from the MENU.

1. Press the **Menu** key.
2. Select PRINTING
3. Select CHANGE INK CARTRIDGE / PRINTHEADS.
4. Select CHANGE PRINTHEADS
5. Remove the Print heads:

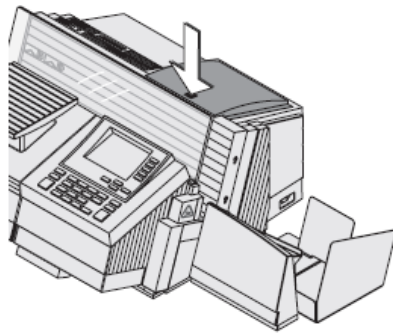

Removing the print heads

- Open the flap by pressing the release key.

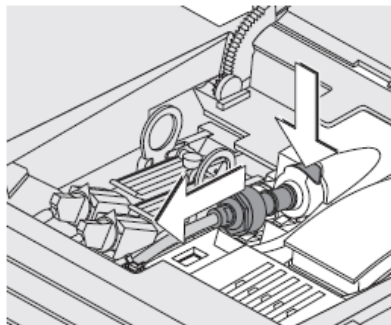

Disconnect hose couplings:

- Hold an absorbent cloth ready.
- Press to release and remove the coupling to the front.
- Wipe the hose coupling with an absorbent cloth.
- Disconnect the coupling of the second hose in the same way.

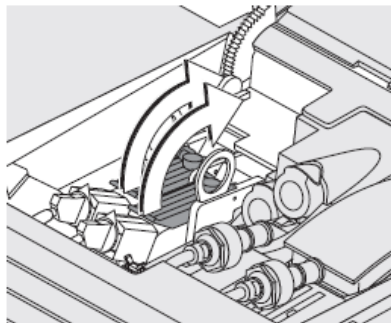

Release the print heads:

- Turn the two blue-green levers upwards.

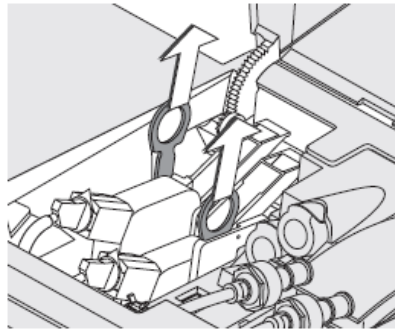

- Pull both lifters (blue-green) upwards.
The print heads are lifted from their brackets.

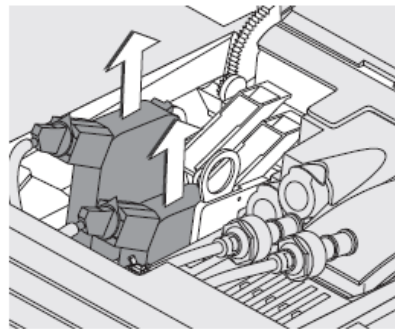

- Pull both print heads upward out of the bracket.
- Confirm the completion of each step with CONTINUE.

Inserting new print heads



Caution! Insert the print heads only after they have adapted to the ambient temperature of the postage meter (e.g. after storage in the basement or after transport in a cold vehicle). Else, no correct calibration can be performed.

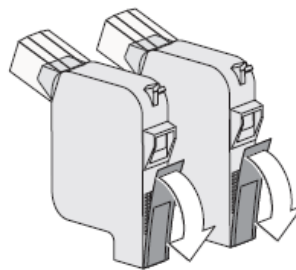

- Unpack the new print heads.
- Remove the protective strip from the print heads.

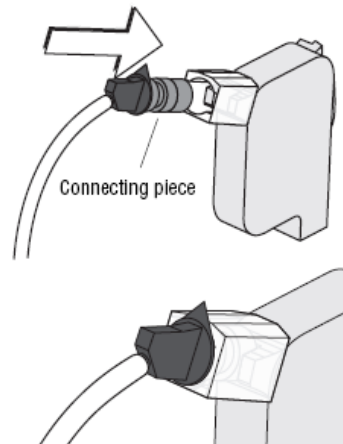

Connect the hose to the print head:

- Hold the connecting piece on its black handle and plug onto the print head as shown.

The hose is correctly connected to the print head if the connecting piece is fully within the transparent shaft.

- Connect the hose of the second print head in the same way.

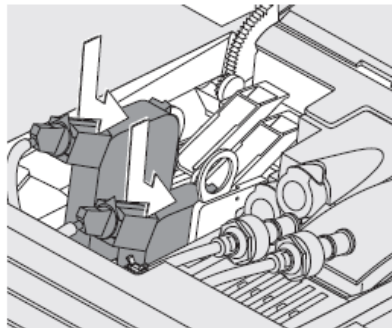

- Hold the print head with its connectors facing backwards, i.e. towards the back of the mailing system.

- Insert the print head into its bracket.

- Push down the print head as far as it goes.

- Finally push the print head back gently – it will then tilt into the bracket.

- Insert the second print head in the same way.

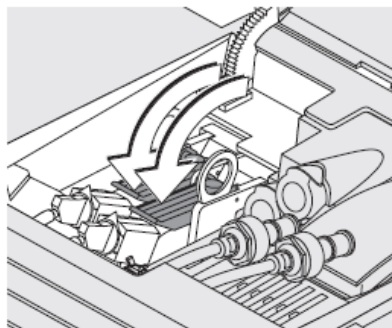

- Lock the print heads: Turn the two blue-green levers downwards.

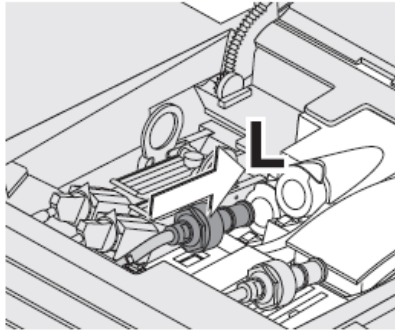

- Plug the hose coupling of the **left** print head into the socket marked with **L** and push in firmly. Feel the coupling lock in place.

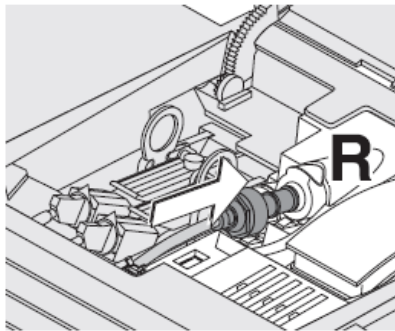

- Plug the hose coupling of the **right** print head into the socket marked with **R** and push in firmly. Feel the coupling lock in place.

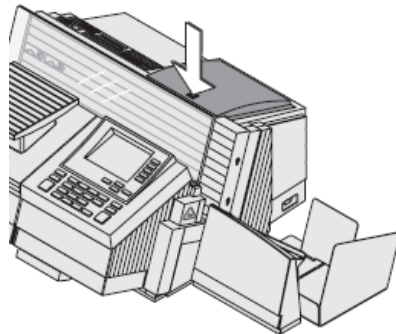

- Close the lid. Press the release key to lock the lid.
- Confirm the completion of each step with CONTINUE.

Note:

If the flap cannot be closed correctly, adjust the position of the hoses by gently turning the black handles on the connection pieces.

Calibration The print heads are calibrated after the exchange procedure. See the display to monitor the process. Please wait until the calibration has finished.

Cleaning After calibration, the print heads are cleaned. The cleaning procedure is automatically performed.

Adjusting the print heads

centormail continues with the print head adjustment procedure: It tells you to position a letter.

- Position an empty envelope for the test print.

centormail generates the test imprint.

- On the test imprint, determine the numbers next to which
 - the horizontal bars are best aligned to each other and
 - the vertical bars are best aligned to each other.

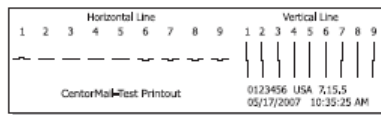

Print heads correctly aligned

If the horizontal and vertical bars form a straight line below number 5, the print heads are correctly aligned.

- Press FINISH to complete the procedure.

Print heads not correctly aligned

If the horizontal and vertical bars do not form a straight line below number 5:

- Press CONTINUE to proceed with the adjustment procedure.

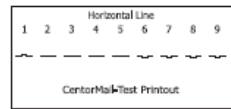

Horizontal line

- Enter the number below which the horizontal bars are best aligned to each other.
(If necessary: Press **C/CE** to delete the displayed number.)
- Press CONTINUE to proceed.

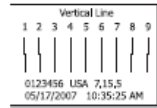

Vertical line

- Enter the number below which the vertical bars are best aligned to each other.
(If necessary: Press **C/CE** to delete the displayed number.)
- Press CONTINUE to proceed.
- Position an empty envelope for the new test print.
- Check the test print. If necessary, repeat the adjustment procedure until the print heads are correctly aligned.